

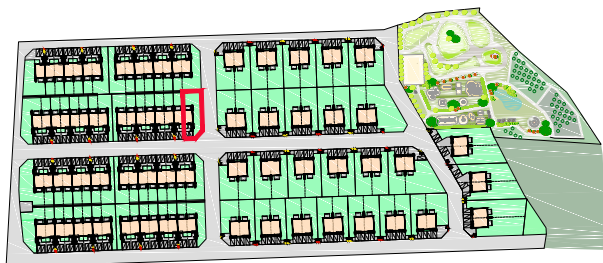

### LOKAL A24P

BUDYNEK	<b>A24</b>
LOKAL	<b>PRAWY</b>
POWIERZCHNIA UŻYTKOWA	<b>86,25 m<sup>2</sup></b>
POWIERZCHNIA DZIAŁKI	<b>377,50 m<sup>2</sup></b>
LICZBA POKOI	<b>4</b>

### PLAN OSIEDLA



### PLAN DZIAŁKI

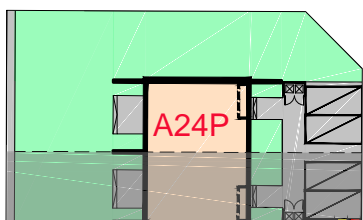

### RZUT PARTERU

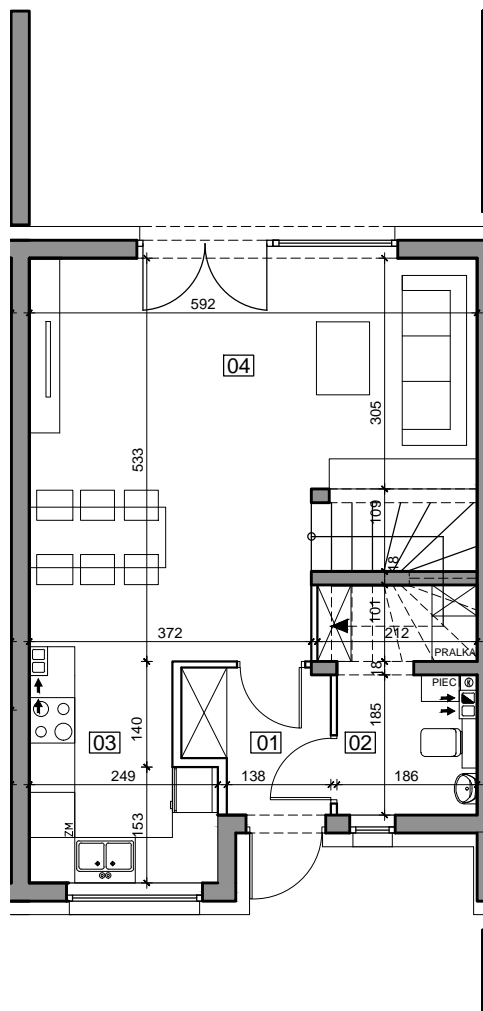

#### PARTER

LP	POMIESZCZENIE	POW.
01	WIATROŁAP	3,26 m <sup>2</sup>
02	WC + POM. GOSPODARCZE	4,67 m <sup>2</sup>
03	KUCHNIA	6,27 m <sup>2</sup>
04	POKÓJ DZIENNY Z JADALNIĄ	26,06 m <sup>2</sup>

**RAZEM PARTER 40,26 m<sup>2</sup>**

### RZUT PODDASZA

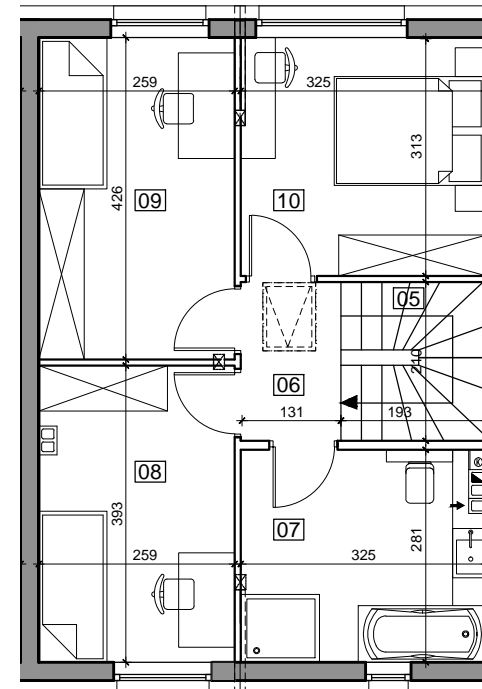

#### PODDASZE

LP	POMIESZCZENIE	POW.
05	SCH. WEWNĘTRZNE	3,98 m <sup>2</sup>
06	KORYTARZ	2,69 m <sup>2</sup>
07	ŁAZIENKA	8,75 m <sup>2</sup>
08	POKÓJ 1	9,87 m <sup>2</sup>
09	POKÓJ 2	10,82 m <sup>2</sup>
10	POKÓJ 3	9,88 m <sup>2</sup>

**RAZEM PODDASZE 45,99 m<sup>2</sup>**

0 1 2 3 4 5m